

MT5-FX2N-3M

MT5-Cable Direct connect MT500
& MITSUBISHI FX Series



Introduction :

MITSUBISHI FX series PLC include FX0/FX0s/FX0n/FX1s/FX1n/FX2nc/FX2n CPU port connect to MT500 PLC485 port or use MT8-COM3 connect to MT8000 COM1 485 or COM3 485.

Specification:

I/F Type: RS485w
MHI port: 9Pin D-SUB Female
PLC port: 8Pin Mini Din Male
Cable Length: 300cm

Wiring diagram:

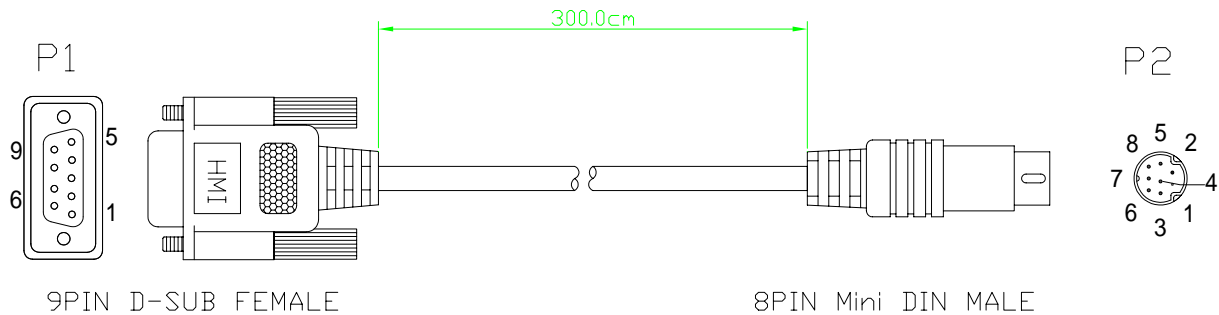

MT500 PLC
RS485
9pin D-sub

1	RX-
2	RX+
3	TX-
4	TX+
5	GND

MITSUBISHI PLC
FX series CPU
RS422 port
8pin mini-Din

4	TX-
7	TX+
1	RX-
2	RX+
3	GND

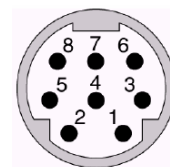

8pin mini-din 8 female port

Mt8000 HMI

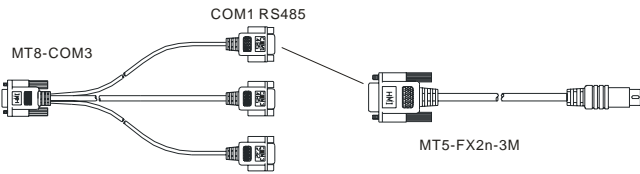

MITSUBISHI FX Series CPU